

# HB-Therm<sup>®</sup>

## VARIO-5

### Switching Unit for Variothermal Control

Product Catalogue 2026-01



## Switching Unit Vario-5

Special challenges in injection moulding cannot be overcome with classical mould temperature control. The solution is a variothermal control: High temperature during injection, cold temperature in the cooling phase.

Together with two temperature control units Thermo-5, the Vario-5 forms a variothermal system according to the fluid-fluid technique. Alternatingly, it links either the hot or the cold unit to the same circuit. It is quite possible to use existing moulds if the temperature control channels are suitably arranged.

Vario-5 provides easy and quiet operation. It supports the user in determining the optimum settings.

### ...after the heat, stay cool!

Improved part quality

- Eliminate weld lines
- Contour accuracy in the moulding of minute structures
- Optimal surface quality
- Reduce sink marks

Improved temperature control

- Short heating and cooling times
- Optimize cycle time and quality

### ...standard temperature control units mean minimal investment

- Multiple use of the units, also for standard applications
- Use of existing temperature control units
- Cost friendly concept
- Much experience with proven systems

### ...small, clean and quiet

Squeezes into almost everywhere

- Made possible by ingenious hydraulic modules

Can also be used in a clean room

- Fibre-free insulation, abrasion resistant castors and high-gloss finish

Silent

- No pressure shocks
- Without compressed air

### ...precise, powerful and efficient

Highly accurate process management

- Switching procedures are monitored

Smaller heating and cooling power requirement

- Integrated energy buffer

### ...safe, reliable and low on maintenance

Fully automated process monitoring

Durable construction

- Solely non-corroding materials in the hydraulic circuit
- Switching without pressure shocks

Improved protection for the mould

- Closed system without oxygen contact
- Avoids steam, scaling and corrosion

### ...easy, intelligent and convenient

- Central command via only one unit Thermo-5 or control module Panel-5
- Clever wizards determine setpoint temperatures, delays and switching times
- Freely selectable control mode
- Recording of data via USB and analysis in Excel

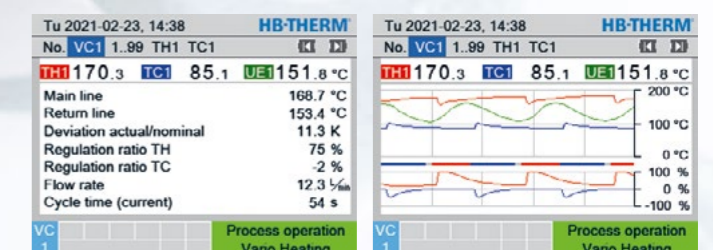

### Standard Equipment

<b>Hydraulics</b>		Closed hydraulic system without oxygen contact Energy buffer  Maintenance-free, pressure shock-free Hydraulic circuit made of non-corroding materials
<b>Functions</b>		Wizards determine setpoint temperatures, reaction times and switching times
<b>Monitoring / Safety</b>		Monitoring of the switching procedures Automatic limit value settings for temperatures and flow Electrically operated valves (no compressed air) Lockable and abrasion resistant castors (PUR) Fibre-free insulation
<b>Command / Display</b>		Large choice of display windows and values Store function for variothermal specific parameters Data recording Status light
<b>Interface</b>	HB (IN/OUT)	HB-Therm data interface CAN for connection to a temperature control unit Thermo-5 or control module Panel-5 2 sockets Sub-D 15 pin (1 male and 1 female)
	Typ J, K, T, Pt 100	Connection for external sensor connector (thermocouple or Pt 100 in 3-wire circuit) 1 socket Audio 5 pin (female), connector 90° (male) included
	0–10 V, 4–20 mA	Connection for external sensor (standard signals) 1 socket M12, 8 pin (female)
	Ext. Control	5 digital inputs and 2 digital outputs for switchover commands via potential-free contact (pulse or continuous contact) 1 socket Harting Han 12Q (female), connecting cable 10 m with plug incl.

Communication (P. 6, Fig. 1)



### Services

Optional services for variothermal applications on a time and material basis:

- Assessment of variothermal application based on mould data (approx. 1 day)  
The current injection moulding application is assessed in terms of variothermal control. This gives an assessment of whether the desired objectives can be met and with which equipment.
- Moulding support of the variothermal process (approx. 1 day)  
Planning and documentation of trial series, running trials, production support and optimisation

### Technical Specifications

<b>Switching unit</b>	Heat transfer medium		Water
	Maximum main line temperature	°C	180
<b>Type</b>			<b>HB-VS180</b>
<b>Energy buffer</b>	Volume 0,9 L	<b>US1</b>	●
	Volume 1,8 L	<b>US2</b>	○ <sup>1)</sup>
<b>Accessories</b> <sup>2)</sup>	Connection set (hydr.) Vario-5/Thermo-5, housing size 1 or 2; 3 m (insulated hoses)	O/ID	T26847-901
	Connection set (hydr.) Vario-5/Thermo-5, housing size 3; 3 m (insulated hoses)	O/ID	T26848-901
	Connection set (hydr.) Vario-5/Mould; 2 m (male adapters for mould G½ incl., insulated hoses)	O/ID	T26841-701
	Cable HB, 5 m	O/ID	T24858-3
	Cable HB/CAN, 5 m	O/ID	T26825-1
	Cable CAN, 5 m	O/ID	T22571-1
	Proximity switch with magnetic base, 10 m	O/ID	T26821-10
	IR-Temperature sensor with magnetic base, 10 m	O/ID	T26819-10
	Emissivity sticker 25 mm (7 pieces)	O/ID	T26843-1
	Mains-connector Type J (Swiss Type 12) 230 V, 10 A; LNPE	O/ID	T27551
	Mains-connector Type F (Schuko) 230 V, 16 A; LNPE	O/ID	T27550
	<b>Services</b>	Assessment of variothermal application based on mould data	O/ID
	Moulding support of the variothermal process	u/ID	T26845

**Ordering example: HB-VS180-US1, English** (without accessories)

Dimensions (P. 7, Fig. 2)	Height	mm	484
	Width	mm	240
	Depth	mm	675
Weight max.		kg	39
Connection, Input/Output (H/C/M)			G¾
		bar, °C	25, 200

● Standard specification    ○ Optional

<sup>1)</sup> Recommended for mould circuits of 0,9 L and larger

<sup>2)</sup> For detailed information and other lengths: Accessories program (D8064-EN)

### Recommendation for Unit Type Thermo-5

Hot water circuit	Thermo-5, HB-160 or HB-180, pump 4M, heating and cooling power depends on application
Cold water circuit	Thermo-5, HB-140, pump 4M, heating and cooling power depends on application
	If the unit for the hot water circuit runs over 160 °C, the unit for the cold water circuit must be equipped with a 17 bar safety valve and a manometer 25 bar (not possible for housing size 1).
Communication	Interface equipment for singular units: Interface HB and interface CAN ( <b>ZC</b> )

Note: In order to ensure compatibility, detailed clarification must be obtained for equipment that differs from this recommendation.

## Communication (Fig. 1)

Basic circuit diagram

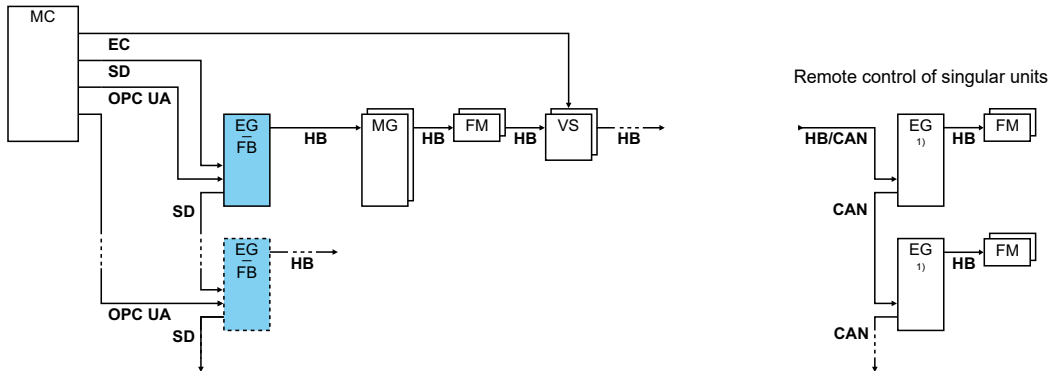

## Examples

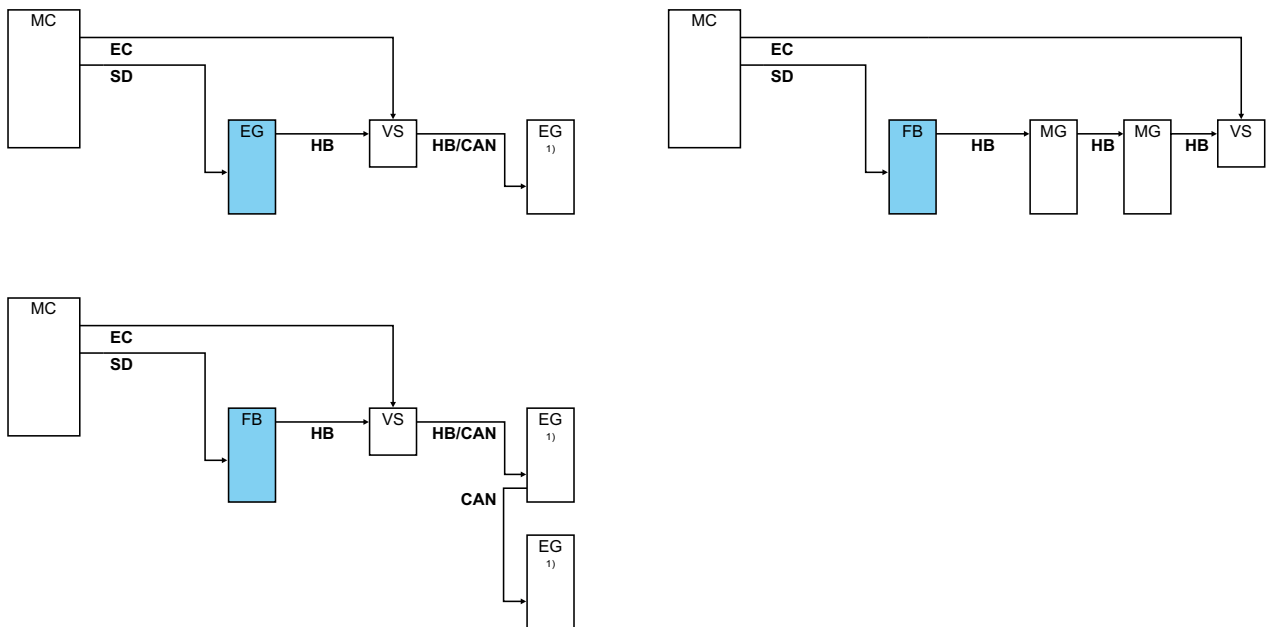

Legend	Description	Note
MC	Machine control	max. 1
FB	Control modul Panel-5	max. 1
EG	Temperature control unit Thermo-5, singular unit	max. 16 (per command)
MG	Temperature control unit Thermo-5, modular unit	
FM	Flow meter Flow-5	max. 32 (at 4 circuits each)
VS	Switching unit Vario-5	max. 8
SD	Communication via serial data interface DIGITAL (ZD), CAN (ZC), PROFIBUS-DP (ZP)	Maximum number of units, operating range and transfer of flow rate values depend on machine control and protocol
OPC UA	Communication OPC UA via Ethernet (ZO)	
HB <sup>2)</sup>	Communication interface HB	Order of connection is not relevant
HB/CAN <sup>2)</sup>	Communication interface HB/CAN	To remotely control singular units
CAN	Communication interface CAN (ZC)	
EC	External control	Assignment dependent on machine control unit

■ Command    <sup>1)</sup> Command deactivated    <sup>2)</sup> max. length cable HB: Total 50 m

### General Technical Data

Power supply	Mains voltage	100–240 V, 50/60 Hz
	Mains cable to unit	LNPE, 4 m (plug on request)
Environment	Temperature range	5–40 °C
	Relative humidity	35–85 % RH (non-condensing)
Colour	Cover	RAL 7035 (glossy light grey), RAL 5012 (glossy light blue)
	Access cover	RAL 7021 (glossy black grey)
Protection class		IP 44
Standards		EN IEC 61000-6-2, EN IEC 61000-6-4, EN IEC 63000, EN 60204-1, EN ISO 13732-1, EN ISO 12100
Certification/Approval		CE (compliance with relevant CE directives)
Temperature measurement	Resolution	0,1 °C
	Tolerance	±3 K

### Dimensions (Fig. 2)

HB-VS180, scale 1:10

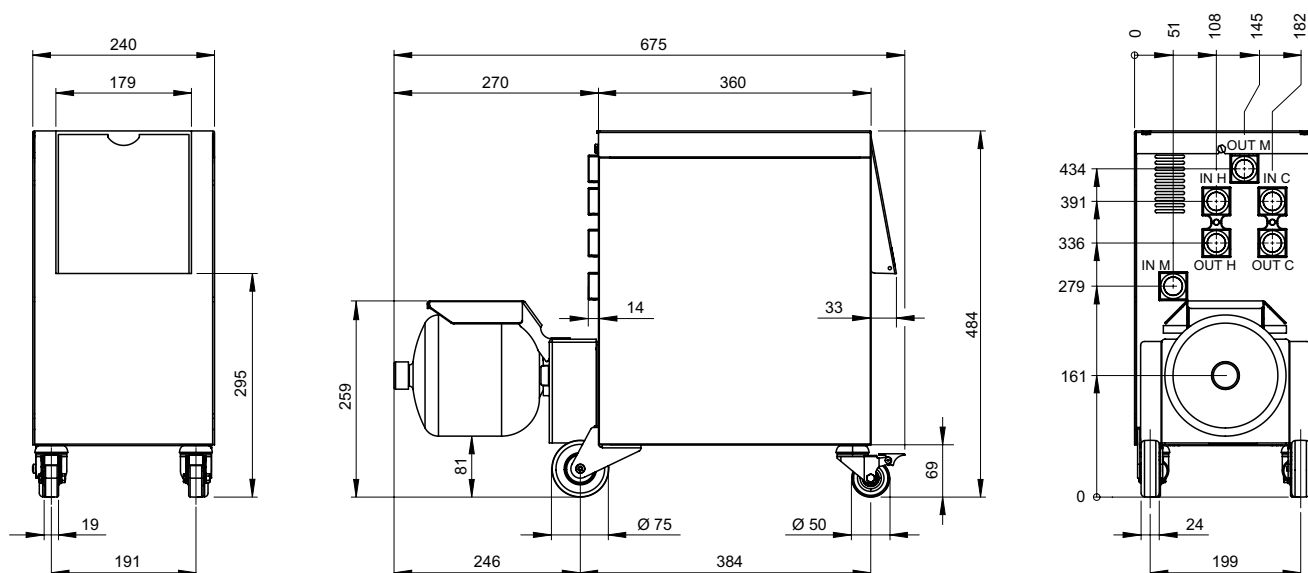

IN H Input hot water circuit  
OUT H Output hot water circuit

IN C Input cold water circuit  
OUT C Output cold water circuit

IN M Input mould circuit (from mould)  
OUT M Output mould circuit (to mould)



# Variothermal Control

In injection moulding some typical problems cannot be solved by traditional temperature control:

- visible weld lines in optically critical areas.
- incomplete moulding of the finest structures and lacking contour accuracy (e.g. for optical lenses, micro- or nanostructures, piano lacquer)
- insufficient surface quality of foamed and fibre-reinforced parts
- excessively high injection pressures for extremely small cross-sections
- sink marks at extreme wall thickness ratios

Reasons: In injection moulding the hot plastic melt meets a relatively cool mould surface in the injection phase. The latter needs to be cool in order to dissipate the heat out of the melt to solidify the part. The mould temperature depends not only on the material, but also on the demands of the component quality and the cycle time. At high temperatures the quality of the component increases, thus longer cycle times are necessary. This negatively affects the unit costs. Therefore, the choice of the mould temperature is always a compromise between quality and cost effectiveness.

If no optimum quality is achieved with a compromise or impermissible process parameters would be needed, an alternative temperature control strategy is necessary. A high temperature during injection followed by a cold temperature in the cooling phase can be a solution. It is called a variothermal control. Two temperature control units, one operating at a higher and one at a lower temperature combined with a switching unit will solve such demanding tasks.

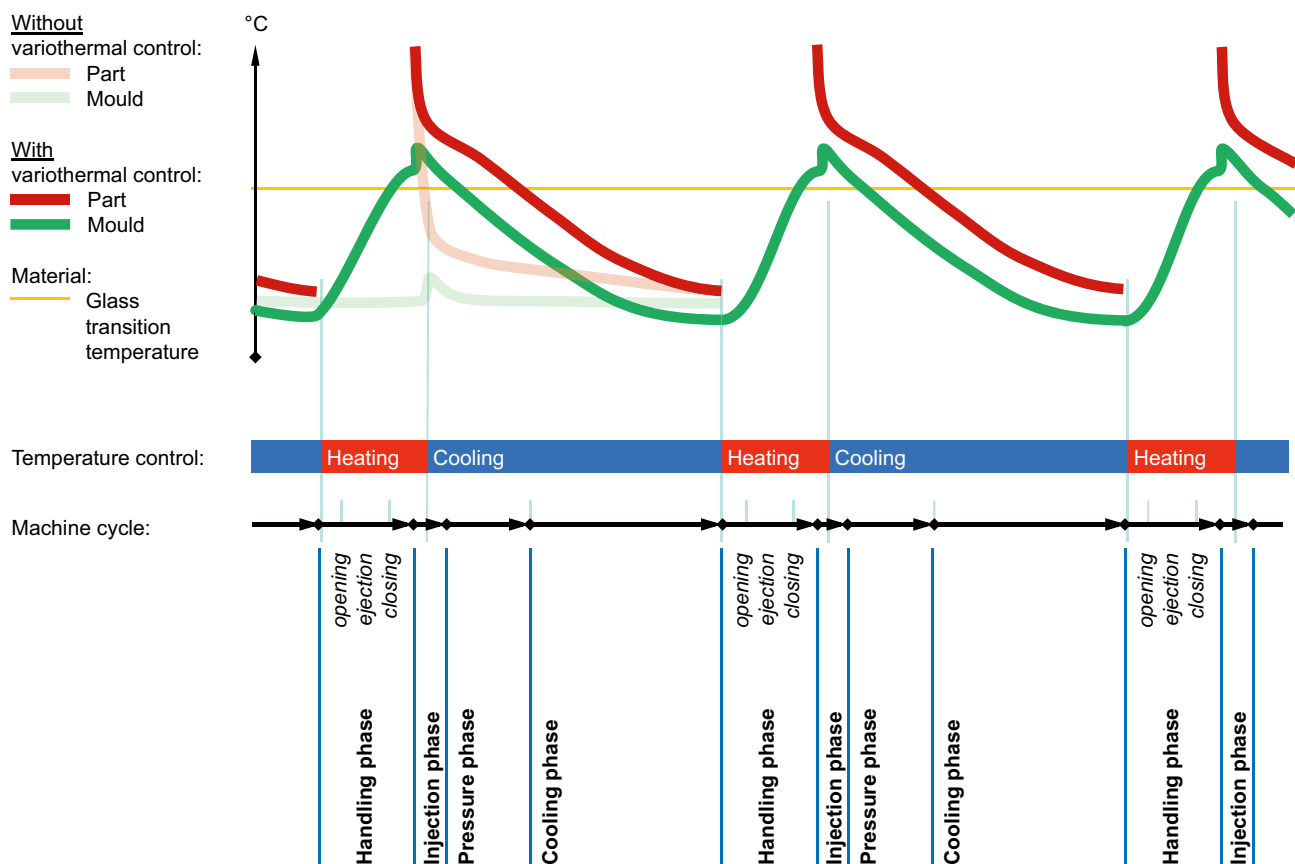

Process procedure in injection moulding with variothermal control

### The Process

The fluid-fluid technique sends alternately hot and cold temperature control medium through the temperature control channel immediately below the cavity surface, controlled by the machine cycle. The temperatures are set on the two temperature control units. If there is a temperature sensor available at a suitable position in the mould, the switch-over or the start of injection can also be made depending on the mould temperature to increase process reliability.

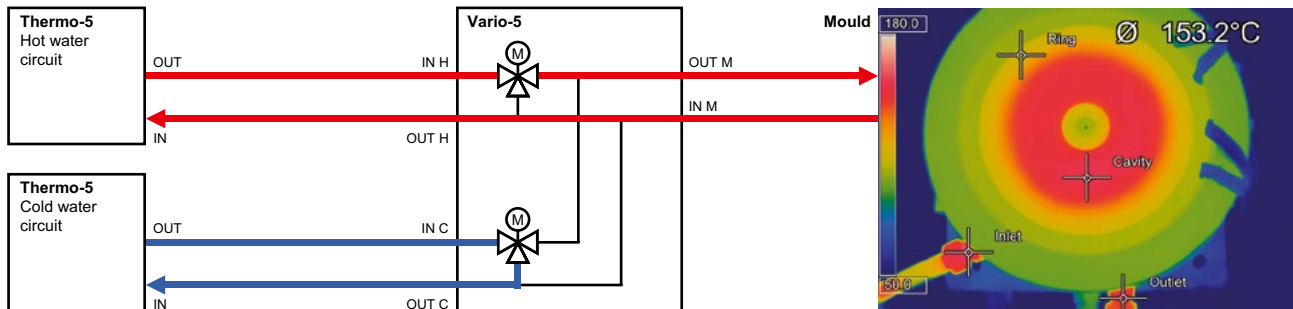

Operating mode: Heating

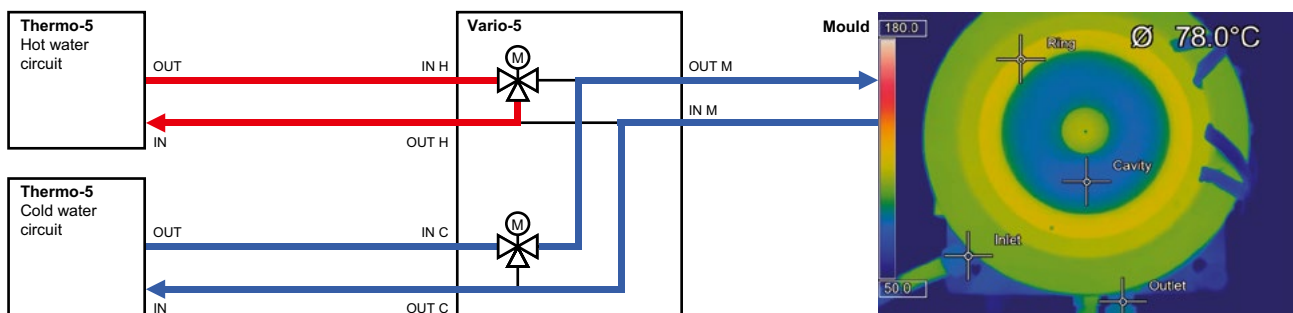

Operating mode: Cooling

### Control

Cyclic heating and cooling is synchronised with the cycle of the injection moulding machine. The highest temperature is reached in the injection phase, the lowest at the time of demoulding. For this purpose, the signals for the switch-over have to precede by the amount of the system delay.

The parameters relevant to the injection moulding process such as injection, holding pressure or cooling time are set via the machine controls. Therefore it suggests itself that the signals for controlling the switch-over should also be set via the machine controls. For this, digital output signals of the machine can be used. Depending on the machine type, values for the variothermal process can be set more or less comfortably.

If only one signal is available for the synchronisation with the injection moulding process the respective delay times in relation to the machine signal must be set on the variothermal equipment. Although the machine interface thus is much simpler it has the distinct disadvantage of having to adjust the settings on the variothermal equipment as well when changing the machine settings.

The timer signals for heating and cooling are independent from the actual temperature in the mould. A separate temperature sensor is not necessary. Software wizards help to determine the necessary delays in a simple way.

Note: Temperature-controlled actuation on demand

### Frame Conditions

In variothermal control the temperature at the surface of the cavity will be actively changed within the injection cycle. The area around the cavity is thus cyclically heated and cooled. Depending on the configuration of the temperature control channels the temperature at the surface of the cavity reacts stronger or weaker and the area is larger or smaller.

To efficiently achieve the largest temperature gradients possible the following is recommended:

Distance of the temperature control channel from the surface of the cavity	The distances between the temperature control channel and the cavity must be kept as small as possible.
Variothermal mass	Keep the variothermal area as small as possible: <ul style="list-style-type: none"> <li>• Run only those circuits on variothermal process which have an influence on the critical mould area</li> <li>• As possible, create inserts that are small and can be thermally isolated from the rest of the mould.</li> </ul>
Isolation	Isolate the variothermal areas with isolating materials or clearances from the rest of the mould.
Connections	Connect the variothermal areas (inserts) directly with specific pipes not in contact with the rest of the mould (clearance) to the temperature control system. Avoid supply via the mould plates or frames as well as heavy distribution and measuring systems, as they will unnecessarily increase the variothermal mass.
Material	In critical cases, inserts of copper alloy or other materials with good thermal conductivity are to be used for the variothermal areas. (The thermal conductivity of copper is more than five times greater than that of steel.)
Temperature control channel cross section	Large channel diameters or several channels increase the surface and thereby the transfer of heat.
Flow rate	The temperature control channels should be designed to achieve the best possible flow rate. This improves the transfer of heat between the temperature control medium and the mould and results in shorter response times or quicker temperature gradients in the mould.

Note: Variothermally controlled circuits can come up to the temperature of the hot unit. Seals, couplings, hoses need to be selected accordingly. The cyclical temperature changes can cause moveable inserts such as sliders to jam.

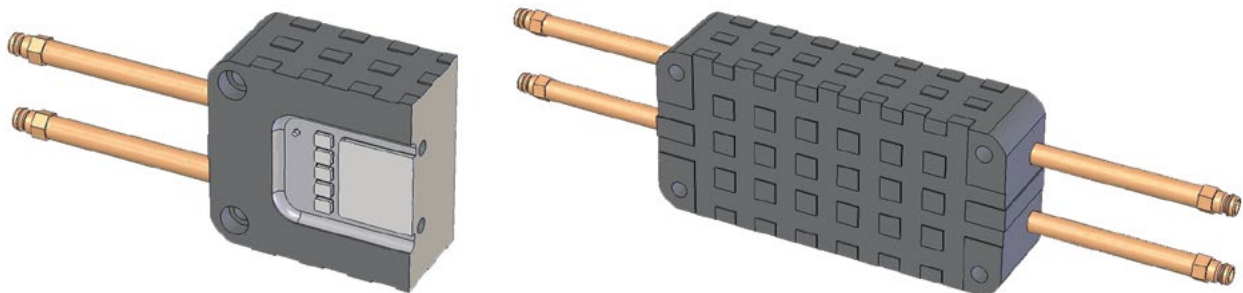

Example for the design of a mould-insert for variothermal control





## HB-Therm Distributors in over 60 countries.

Algeria  
Argentina  
Australia  
Austria  
Belgium  
Bolivia  
Bosnia and Herzegovina  
Brazil  
Chile  
China  
Colombia  
Costa Rica  
Croatia  
Czech Republic  
Denmark  
Ecuador

El Salvador  
Estonia  
Finland  
France  
Germany  
Great Britain  
Guatemala  
Hong Kong  
Hungary  
India  
Indonesia  
Ireland  
Israel  
Italy  
Japan  
Korea

Latvia  
Liechtenstein  
Lithuania  
Luxembourg  
Malaysia  
Mexico  
Morocco  
Netherlands  
New Zealand  
North Macedonia  
Norway  
Paraguay  
Peru  
Poland  
Portugal  
Romania

Serbia  
Singapore  
Slovakia  
Slovenia  
South Africa  
Spain  
Sweden  
Switzerland  
Taiwan  
Thailand  
Tunisia  
Turkey  
Uruguay  
USA  
Venezuela  
Vietnam



Contact  
details